

ShockWater CarWash Systems

SWCWS ReGen III w/ Post Polishing Filter

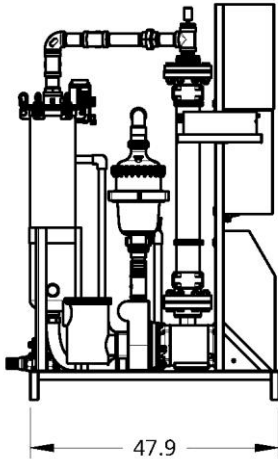

Front View

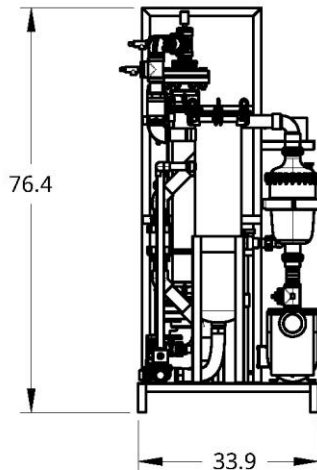

Side View

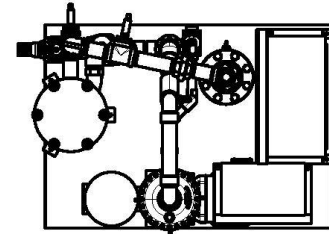

Top View

ReGen III Description

The SWCWS ReGen III uses our patent pending (US and International) high performance Advanced Oxidation Process (AOP) technology. Derived from treating oil field water the AOP is uniquely applied in the car wash water treatment market. Our AOP technology converts organic compounds such as surfactants, waxes, and even microbial matter into products of combustion: Carbon Dioxide and water.

How It Works

To begin: contaminated wash water is collected post vehicle washing. From there ReGeneration of the wash water begins in the underground separators / storage tanks and concludes in the above ground produced water storage tanks. This process consists of a series of stages to simultaneously remove both suspended, low density and dissolved solids. Solids are made up of particulates that range in density from the same as water to heavier than water. This requires different techniques to remove.

Suspended solids: larger than 5 mm and heavier than water is removed through the cyclonic separator.

Low-density: an optional Pre-Filter removes these solids which tends to clog nozzles and other process related issues.

Dissolved solids: are removed by chemical oxidation through the combined application of our proprietary E-Cell technology and Ozone.

Water is ReGenerated through the entire water cycle 24/7: a portion is sent to the underground tanks for anti-microbial treatment and odor control; the balance of the ReGenerated water is passed to the produced water reservoir for residual treatment prior to re-use.

The final stage of the SWCWS ReGen III process: is fine filtration where any remaining or coagulated particulate larger than 5 mm is removed. This leaves a clean, clear water with no odor held in the above ground produced water storage tanks.

Performance Data

- Treats 110 gpm
- 25 gpm of filtered, Advanced Oxidation Water is fed to the underground storage tanks.
- 85 gpm of filtered, Advanced Oxidation Water is supplied to the produced water storage tanks for all washing operations
- Ozone Generation Injection (ozone safety monitor)

Specifications

Skid and Frame are 304 stainless steel.

- * H: 76 1/2" W: 48" D: 34" weight 475 lb (shipping weight 625 lb.)
- * Input power: 208/230/480 volt, 3 phase @ 19 / 16 / 8 amp max
- * Control Power: 115 vac, 15 amp max
- * On/Off Control: Switch selectable Off/On or remote
- * Primary Pump: 5 HP pump, 110 GPM @ 50 PSI VFD Driven
- * Inlet Filtration: Cleanable Basket Strainer

Filtration system

Primary: Automatic Self-Purging Vortex Filter – 95% at 5 mm sand particle

Optional Pre-Filter: Automatic Backwashing – 25 micron filtration

Polishing: Automatic Backwashing – 25 micron filtration

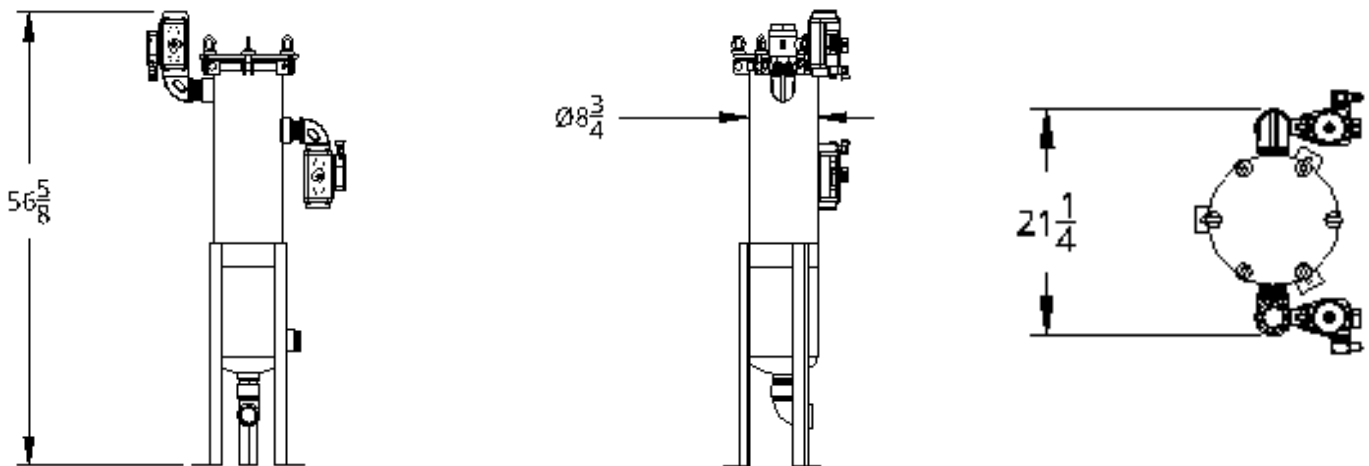

Front View

Side View

Top View